

INTEGRATED APPLIANCES

SIKB 3550



Watch the
integration
ventilation video
here
<https://youtu.be/R0emxcVnj4w>



LIEBHERR

Quality, Design and Innovation

LIEBHERR 60CM INTEGRATED REFRIGERATOR SIKB 3550



Bio Fresh

Soft Telescopic

Soft System

3 Year Warranty



Model	SIKB 3550
Type	FI
Finish	Own cabinetry
Energy consumption (kWh/yr) Star rating	328kWh 1.5
Compressors	1
Total capacity litres (L) - Gross Net	344 308
Refrigerator gross (L) net (L)	245 216
BioFresh gross (L) net (L)	99 / 92
MagicEye control system Display	SoftTouch LCD
Child proof setting for display & temp.	•
Premium	•
SoftSystem hinge - assists closure	•
Door open warning signal	•
Malfunction warning signal	•

Refrigerator Features

BioFresh drawers on telescopic rails	3
SuperCool	•
GlassLine shelves	•
VarioSafe	•
Elegant holding columns	•
Bottle shelf Egg tray	Integrated •
Automatic refrigerator defrosting	•

Technical Information

Default hinge	Right
Voltage (V) Rated Input Power (W)	220-240 192
Made in	Germany

KEY: FI = Fully Integrated. Door hinging either right or left hand must be nominated for this model.

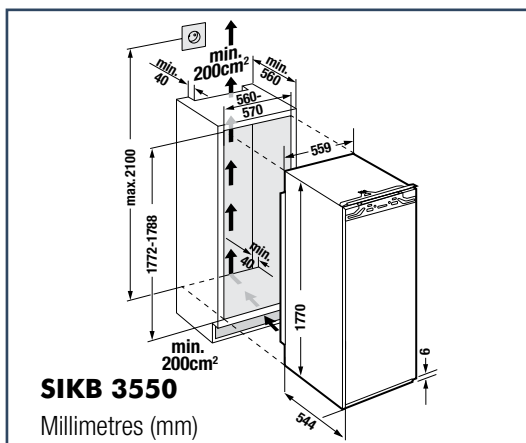

Whilst every effort is made to ensure all specifications and information in this flyer are correct at time of printing, Andico Australia Pty. Ltd. reserve the right to make changes without notification. Where actual appliance measurements, specifications and ratings are crucial, we recommend that the actual appliance installation instructions that accompany each appliance be checked. Andico Australia will not be liable for any loss.

ATTENTION:

CABINET MAKER / INSTALLER / BUILDERS IMPORTANT INFORMATION ABOUT VENTILATION FOR INTEGRATED APPLIANCES

Following the installation instructions that accompany a Liebherr integrated appliance is extremely important. Ventilation is imperative for the correct operation of Liebherr integrated appliances. It is essential that installers ensure minimum ventilation is provided in accordance with the installation manual that accompanies the actual appliance. Appliance faults resulting from incorrect installation or inadequate ventilation may not be covered by warranty. Please read the below information for a brief overview of installing integrated appliances.

Installation

- In a multiple unit installation each unit must be installed in a separate cabinet.
- Maximum cabinet and door panel thickness is 19mm (where applicable).
- The doors of units with two doors must not be joined together with a single joinery panel (where applicable).
- Joinery door panels must not exceed the admissible weight of the unit door (where applicable).

Ventilation

- **Minimum 200cm²** ventilation openings must be provided at both top and bottom of cabinet.
- The ventilation path must maintain a minimum cross-section of 200cm² flow and return into the room.
- Room must be a habitable room (excluding bedrooms) of not less than 50m³ volume.
- When fitted, each ventilation grill must have a minimum open area of 200cm².
- Ventilation openings provided for other appliances must not adversely affect the refrigeration unit ventilation.
- Failure to provide adequate ventilation can damage the appliance.

General Installation Information

- Power outlet must be accessible. Do not install within the unit cabinet.
- Water supply point must be accessible. Do not install within the unit cabinet.
- Standard water hose length 1.5m. Selected models feature 3.0m hoses. Check specification table for further details.
- 3.0m water hose is available from Andi-Co Australia spare parts at an additional cost.

Operating and installation instructions are available on our website www.andico.com.au. Please note that changes may occur without notice therefore where actual appliance measurements and specifications are crucial, we recommend that the actual appliance installation instructions that accompany the appliance be used.

Design Review Service

Don't void the appliance warranty with inadequate ventilation. Andi-Co Australia offer a design review service. Send your cabinet plans to design@andico.com.au for assessment. We can assist in identifying any deficiencies in the cabinet and ventilation design before you build. Attachments should be in pdf format and include the unit model number/s and ventilation grill specifications.

Ventilation Grills

To ensure adequate ventilation for your Liebherr appliance, it is paramount to install the right ventilation grills. For ventilation grill recommendations please contact Liebherr customer care on 1300 650 020.



Suitable for models requiring 200cm² airflow only

Part No.: YL7427640

Suitable for integrated appliances requiring minimum airflow 200cm²

