

INTEGRATED APPLIANCES

UIK 1620



LIEBHERR

Quality, Design and Innovation

LIEBHERR COMPACT UNDERBENCH REFRIGERATOR UIK 1620

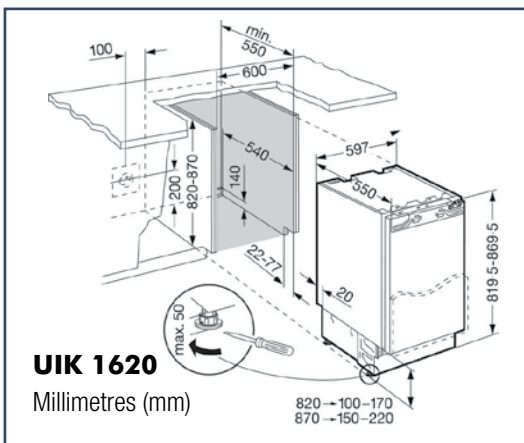

Model	UIK 1620
Type	UB - FI
Finish	Own cabinetry
Energy consumption (kWh/yr) Star rating	153kWh 3.5
Compressors	1
Total capacity litres (L) - Gross Net	140 135
Refrigerator gross (L) net (L)	140 135
MagicEye control system Display	• LED
Child proof setting for display & temp.	•
LED standard lighting	•
115° door opening	•

Refrigerator Features

Fruit & vegetable crisper bin	1
SuperCool	•
GlassLine shelves	•
Elegant holding columns	•
Bottle shelf Egg tray	• •
Automatic refrigerator defrosting	•

Technical Information

Default hinge	Right
Voltage (V) / Rated Input Power (W)	220-240 / 288
Made in	Germany

KEY: UB = Underbench, FI = Fully Integrated.
Door hinging either right or left hand must be nominated for this model.

Whilst every effort is made to ensure all specifications and information in this flyer are correct at time of printing, Andi-Co Australia Pty. Ltd. reserve the right to make changes without notification. Where actual appliance measurements, specifications and ratings are crucial, we recommend that the actual appliance installation instructions that accompany each appliance be checked. Andi-Co Australia will not be liable for any loss.